



Owners Manual



501 TWO-WIRE RTD TRANSMITTER

10750ML-02

*INCLUDES EXTENDED WARRANTY CARD -
SEE END FLAP

TABLE OF CONTENTS

PAGE

1.0 GENERAL INFORMATION

1.1 Accuracy and Stability

1.2 Adaptability/Turndown

1.3 Linearity

1.4 Electrical Isolation.....

1.5 Shock Resistance.....

1.6 Waterproof/RFI-Resistant Case.....

1.7 Mounting Adaptability.....

2.0 SPECIFICATIONS.....

2.1 Input.....

2.2 Output.....

2.3 Accuracy.....

2.4 Environmental.....

2.5 Mechanical.....

3.0 MECHANICAL ASSEMBLY AND INSTALLATION

3.1 Safety Considerations.....

3.2 Optical Adapters for Mounting

3.3 Surface and TR2/2TK Relay Track Mounting

3.4 DIN EN 50 022 Relay Track Mounting

3.5 External Explosion-proof Housing Mounting

4.0 POWER AND SIGNAL INPUT CONNECTIONS.....

5.0 CALIBRATION.....

5.1 Tools and Equipment

5.2 Calibration Procedure

5.3 Pin Assignments

6.0 DRAWINGS 18

APPENDICES

APPENDIX A TRANSMITTER ACCURACY SPECIFICATIONS.....

ILLUSTRATIONS

PAGE

Figure 3-1 Exploded View of Model 501

Figure 3-2 Bulkhead and Track Mounting.....

Figure 3-3 DIN Track Mounting.....

Figure 3-4 Spring Retainer for Explosion-proof Housing

Figure 4-1 Input Connections.....

Figure 5-1 Calibration Setup

Figure 5-2 Calibration Flowchart.....

Figure 5-3 Jumper Diagram

Figure 6-1 501 Case Dimensions

Figure 6-2 501 Preamp Block Diagram.....

Figure 6-3 501 Postamp Block Diagram

Table 5-1 DIN 43760 Pt-100 Resistance.....

Table 5-2 Span Ranges in Degrees Celsius Obtained with Jumpers

Table 5-3 Span Ranges in Ohms Obtained with Jumpers

1.0 GENERAL INFORMATION

The 501 two-wire transmitter supplies a 200-microampere current to the Pt-100 RTD, gauges the resulting microvolts, and provides amplification and common-mode isolation, controlling the current drawn from a 9-to-50 V dc source to produce the 4-to-20 milliampere output signal.

Common-mode voltage between the input RTD and the output current circuit is tested at 1500 V rms. As much as 750 ohms dropping resistance may be used in the power leads of the 501 when the unit is energized from a 24 V dc source because of the small compliance voltage needed by the unit. Accidental overloads of over one minute by 120 V rms on the output leads do not damage the 501.

1.1 ACCURACY AND STABILITY

The 501 has tailored resistance values installed to provide low temperature coefficients and a high degree of lead-resistance-effect rejection in 3 (or 4) -wire configurations. Selected bridge resistors in a temperature-sensing bridge provide cancellation of Span temperature effects. High-ambient-temperature compensation points are checked. The unit is certified for accuracy from -40 to +85°C (-40 to +185°F).

1.2 ADAPTABILITY/TURNDOWN

The Span of the 501 can be ranged anywhere from 100 to 1050°C by selection of four jumper positions, with fine tuning provided by a multiturn, top-accessible potentiometer. Sixteen Zero steps, also provided by 501 jumpers, allow placement of the 4-mA output temperature anywhere from -200 to 750°C, with fine tuning provided by another top-accessible, multiturn potentiometer. This 501 turndown capability exceeds that of any other known RTD transmitter.

1.3 LINEARITY

The span and zero suppression capabilities (high turndown ratio) allow high-gain control for continuous processes and good linearity over narrow temperature ranges. Downstream linearization of the 4-20 mA signal is required for accurate absolute temperature readout over a wide span.

1.4 ELECTRICAL ISOLATION

501 input (2, 3 or 4-wire RTD) and output (DC power) barrier strips accept wires up to 2 mm diameter (13 gauge), and are mechanically isolated from each other to prevent input/output wiring contact during installation.

1.5 SHOCK RESISTANCE

Lightweight 501 circuit boards are formed into a rigid box structure and firmly soldered to the case top. The circuit-board box is doubly coated with RTV silicone for environmental protection. When installed in the rugged, die-cast case, the 501 can withstand the shock of a 6-foot drop onto a hard surface (although scarring of the case and/or deformation of the plastic cover can occur).

1.6 WATERPROOF/RFI-RESISTANT CASE

The 501 case is made from Zamac (zinc alloy), coated with polyurethane, and gasketed with fluorosilicone. Fluorosilicone plugs protect the top-access Span and Zero potentiometers.

1.7 MOUNTING ADAPTABILITY

The small size of the 501 (less than 75 mm or 3 in OD) permits mounting in small spaces, including explosion-proof housings for wiring compatibility with other equipment in hazardous environments. A bulkhead adaptor provides for wall-mounting. A snap-track adaptor mounts on either American or European relay tracks. Tapped holes in the case rear provide for custom mounting on any surface, indoor or out. An optional opaque top cover shields the barrier strips from harsh environments.

2.0 SPECIFICATIONS

2.1 INPUT

Configuration	Isolated input
Sensor types	2, 3 or 4-wire RTD probe or variable resistor (from 0 to 400 ohms, minimum span of 35 ohms)
Input current source	200 μ A nominal
RTD lead resistance rejection	40 dB (balanced 3-wire)
Common mode voltage, input to case	Test, 2100 V peak; IEC spacing for over 354 V peak
Common mode rejection, input to case	120 dB, dc to 60 Hz

2.2 OUTPUT

Linear range	4 to 20 mA dc
Compliance (supply-voltage range)	9 to 50 V dc
Overvoltage protection	120 V ac for 1 minute
Reverse polarity protection	400 V peak
Common mode voltage, output to case	1500 Vp (354 Vp per IEC spacing)
Common mode rejection, output to case	120 dB, dc to 60 Hz

2.3 ACCURACY

Hysteresis and repeatability	Within $\pm 0.2^{\circ}\text{C}$ $\pm 0.1\%$ of span
Six month stability	Within $\pm 0.2^{\circ}\text{C}$ $\pm 0.2\%$ of base temp
Power supply effect	Within 0.01% of span/volt
Ambient temperature effect for 50°C change	Zero error: Within $\pm 0.5^{\circ}\text{C}$ $+0.2\%$ of zero suppression
Span error: Within 0.2% of span	
Response Time (To 0.1% of step)	Typical 200 ms

2.4 ENVIRONMENTAL

Operating temperature	-40 to 85°C
Storage temperature	-55 to 125°C

Humidity	To 100% (splashproof)
Vibration	1.52 mm (.06 in) double amplitude, 10-80 Hz cycled
Shock	55g, half-sine, 9-13 msec duration, 6' drop to hard surface
Watertight pressure limit	35 kPa (5 psi)
Mounting position	Any

2.5 MECHANICAL

Case material	Zamac (zinc alloy), polyurethane-coated, fluorosilicone-gasketed
Weight	380 g (13 oz)
Diameter	74 mm (2.9 in)
Height (including barriers)	52 mm (2.1 in)
Connections	#6 screws with wire clamps

3.0 MECHANICAL ASSEMBLY AND INSTALLATION

3.1 SAFETY CONSIDERATIONS

This instrument complies with required safety regulations. To prevent electrical or fire hazard and ensure safe operation, please follow the guidelines below:

VISUAL INSPECTION: Do not attempt to operate the unit if damage exists. **POWER VOLTAGE:** The power supply range should be 9 - 50 V dc.

POWER WIRING: This instrument has no power-on switch; it will be in operation as soon as the power supply is energized.

SIGNAL WIRING: Make signal connections before power is applied. If connection changes are required, first deenergize the power supply.

EXERCISE CAUTION: As with any electronic instrument, high voltage may exist when attempting to install, calibrate, or remove parts of the transmitter.

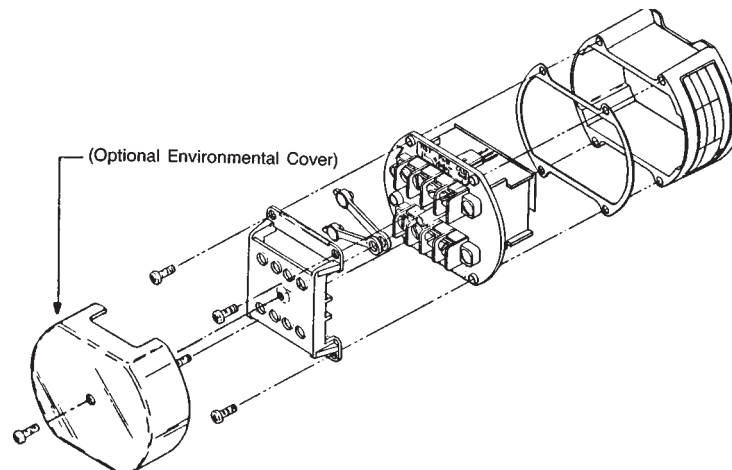

Figure 3-1 Exploded View of Model 501

The low voltage requirement of the 501 enables its use with a current-loop indicator (Newport Model 508 recommended). Tapped holes on the back of the case provide for custom mounting to a flat surface; flanges on the back of the case provide for standard 8TK2 relay track mounting. For flat surface mounting, use #6 hardware. For 8TK2 relay track mounting, simply push onto track.

3.2 OPTIONAL ADAPTERS FOR MOUNTING

The following optional adaptors provide various mounting choices:

- a. Adaptor plate for either front-screw-entry surface mount, or TR2/2TK relay track mount (see Figure 3-2).
- b. Rail clamp for DIN-EN-50 022 relay track mount (Figure 3-3).
- c. Spring retainers for external 76.4 to 88.9 mm (3 to 3.5 in) explosion-proof housing mount (see Figure 3-4).

3.3 SURFACE AND TR2/2TK RELAY TRACK MOUNTING

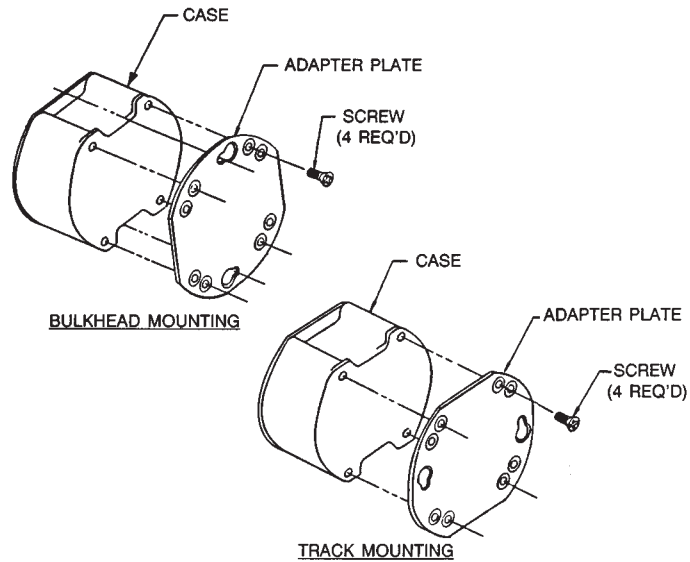

Figure 3-2 Bulkhead and Track Mounting

1. Position plate for desired application.
2. Use #6 hardware to mount plate to back of 501 case.

3.4 DIN EN 50 022 RELAY TRACK MOUNTING

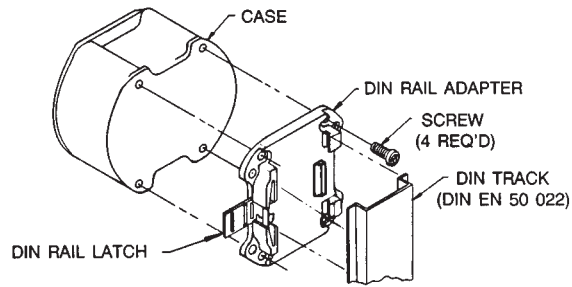

Figure 3-3 DIN Track Mounting

1. Position plate for desired track direction.
2. Use #8 flathead screws to mount plate to back of 501 case.
3. Snap 501 case assembly onto DIN rail.

3.5 EXTERNAL EXPLOSION-PROOF HOUSING MOUNTING

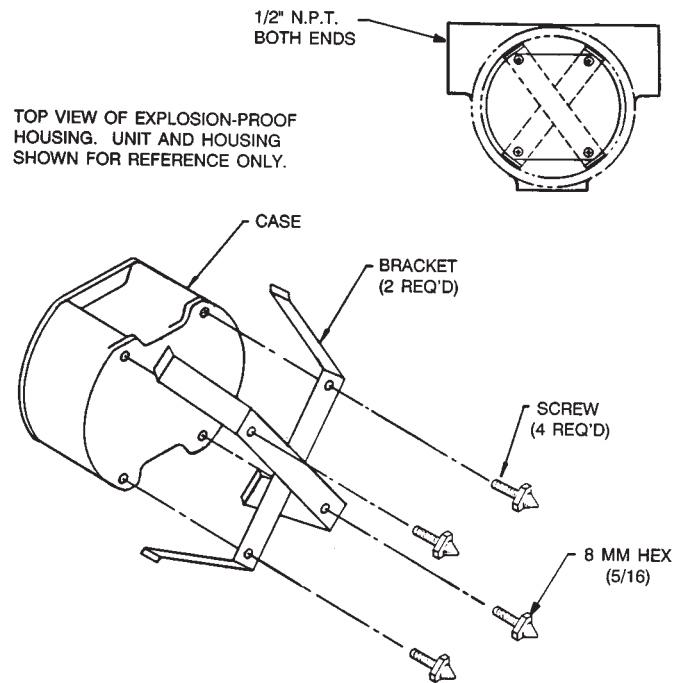

Figure 3-4 Spring Retainer for Explosion-Proof Housing

Figure 3-4 Spring Retainer for Explosion-Proof Housing

1. Position spring retainer across back of 501 case.
2. Use wire protector feet (4 provided with above option) to hold spring retainers in place.
3. Press 501 case assembly into explosion-proof housing.

4.0 POWER AND SIGNAL INPUT CONNECTIONS

TEST, + PWR, and - PWR screws accept 2 mm (13 gauge) or lighter wire. CASE GND is grounded to the case. Power input range is 9-50 V dc.

SCREW-TERMINAL PIN ASSIGNMENT AS SHOWN IN FIGURE 4-1

- 1 TEST
- 2 + POWER/OUTPUT
- 3 - POWER/OUTPUT
- 4 CASE GND

- A +EXCITATION
- B +SENSE (N/C)
- C -SENSE
- D -EXCITATION

The Test function is used to determine if the transmitter is working. Since the 501 is capable of outputting up to 30 mA, the voltmeter should be able to read a current output up to 30 mA (which is 300 mV).

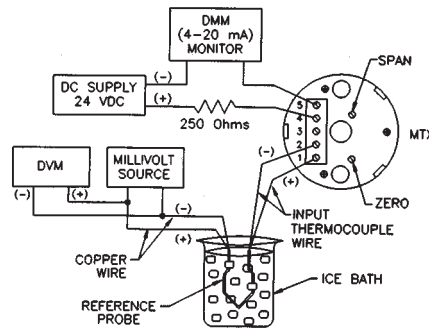

Figure 4-1. Calibration Setup Using a Millivolt Source

Figure 4-1 Input Connections

Figure 4-1 illustrates three ways to perform wire hook-up. The current can be measured using the field voltmeter, a milliammeter, or a millivoltmeter shunted by a known resistor. All three are shown above.

5.0 CALIBRATION

The 501 is normally delivered configured for 4-20 mA = 0 - 850°C.

5.1 TOOLS AND EQUIPMENT

- #1 Phillips screwdriver
- Small flathead screwdriver for potentiometer adjustment
- One 4 1/2 digital ammeter
- Fixed or variable DC power supply or battery (range of 12-30 V dc)
- Decade resistor box (Model 1433T General Radio or equivalent)

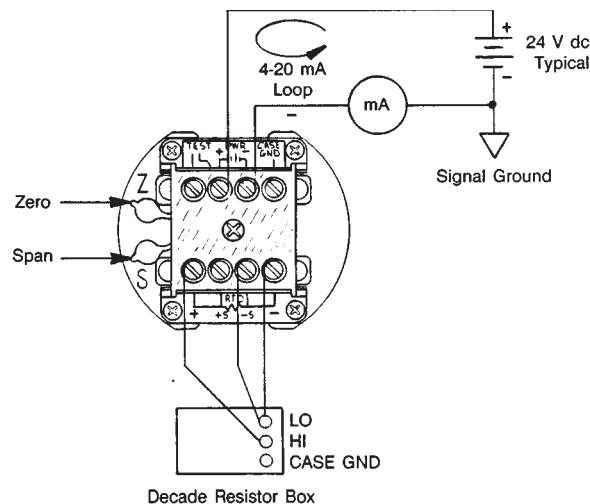

Figure 5-1 Calibration Setup

5.2 CALIBRATION PROCEDURE

1. Refer to Figure 5-1. Remove the four Phillips-head screws from the case top, and set aside the plastic barrier cover. Lift out the electronics assembly (attached to the case lid).
2. Setting aside the case and sealing gasket, pull out the two sealing plugs which cover the Span and Zero potentiometers (pots). Adjust the Span pot to about midway point. (For a 15-turn pot, adjust counter-clockwise approximately 20 turns to reach the farthest right possible. Then begin turning it clockwise 3 turns to engage and another 7.5 turns to reach mid-point.)
3. Attach the resistor box to the 501 between the + (EXCITATION) and — (EXCITATION) terminals (use the — SENSE lead for the 3-wire configuration). If a 3-wire configuration is not desired, — SENSE and — EXCITATION should be connected together at the terminal.
4. From the 501 output terminals, connect the + terminal to the + terminal of a 12 to 30 V dc power supply or battery and the — terminal to the + terminal of an ammeter. Close the 4-20 mA loop by connecting the — terminal of the ammeter to the — terminal of the power source.
5. Refer to Table 5-2 for temperature ranges or Table 5-3 for ohm ranges obtained with Zero and Span jumpers. Turn the 501 so that the jumper pin-forest is in view (Figure 5-3), and place the push-on jumpers in the positions chosen to yield the desired Zero and Span ranges.

NOTE: After jumper installation, reinstall the electronic assembly in the case for the better calibration stability.

6. Turn on the power supply. Set the resistor box to the ohms corresponding to the desired LO temperature or ohms (Zero) from Table 5-1 or Table 5-3, and adjust the Zero pot for 4.00 mA output current.
7. Set the resistor box source to the ohms corresponding to the desired HI temperature or ohms from Table 5-1 or Table 5-3 and read the Temporary Output Current, designated TOC (normally not equal to 20 mA).
8. Calculate: $16 \times \text{TOC} : (\text{TOC} - 4) = \text{CFS}$ (Current Full Scale) milliamperes.
(Generally, CFS will also not be equal to 20.00 mA.)
9. Adjust the Span to display the CFS output on the milliammeter.
10. Now readjust the Zero so that the output reads 20.00 mA.
11. Set the resistor box back to LO temp ohms. If the output current is not 4.00 mA, retrim starting at Item 7, above.
12. When calibrated, turn off the power supply, remove wires, and replace pot sealing plugs. Using the four screws, secure the transmitter in the case with a firmly compressed (but not flattened) gasket for a good seal.

EXAMPLE FOR OHMS:

Ohms range: 200 ohms = 4 mA, 450 ohms = 20 mA

1. Calculate the Span. $\text{Span} = \text{ohms (20 mA)} - \text{ohms (4 mA)}$
 $\text{Span} = 450 - 200 = 250 \text{ ohms}$
2. Refer to the top row of Table 5-3 to find the proper Span jumper, in this case "E" and "H."
3. Using the column labeled "Min Res for 4 mA" in Table 5-3, find the required Zero jumpers for the selected Span. If the resistance corresponding to the 4 mA is between two Zero jumper readings, select the Zero jumper with the smaller reading, in this case "B" and "D." The additional Zero suppression will be obtained by the Zero pot.

Calibrate:

1. Set Span pot to about midpoint.
2. Set the resistor box resistance to 200 _ .
3. Adjust the Zero pot to 4.00 mA.
4. Set the resistor box to 450 _ .
5. Read the current designated TOC.
6. Calculate $\text{CFS} = 16 \times \text{TOC} : (\text{TOC} - 4) \text{ mA}$.
7. Adjust Span pot to obtain CFS.
8. Adjust the Zero pot to obtain 20.00 mA current.
9. Set resistor box resistance to 200 _ .
10. If the output is not 4.00 mA, readjust the Zero pot.
11. Set the resistor box to 450 _ .
12. If the output is not 20.00 mA, readjust the Span pot.
13. Repeat steps 9 through 12 until 4.00 and 20.00 mA are obtained for the corresponding 200 and 450 _ .

NOTE: Steps 1 through 8 are optional as they are meant to reduce calibration time by calculating the offset caused by the interaction between the Zero and Span pot.

EXAMPLE FOR TEMPERATURE:

Temperature Range	=	-200 to 400°C	Zero Jumper	None	Table 5-2
Base Temperature	=	-200°C	Span Jumper	EH	Table 5-2
Top Temperature	=	400°C	Base Temp	18.49 Ω	Table 5-1
			Top Temp (Max)	247.04	Table 5-1

Calibrate:

1. Set Span pot to about midpoint.
2. Set resistor box resistance to 18.49 _
3. Adjust Zero pot to 4.00 mA.
4. Set resistor box resistance to 247.04 _
5. Read current, designated TOC
6. Calculate $\text{CFS} = 16 \times \text{TOC} : (\text{TOC} - 4) \text{ mA}$.
7. Adjust Span pot to obtain CFS.
8. Adjust Zero pot to obtain 20.00 mA current.
9. Set test resistance to 18.49 _ .
10. If the output is not 4.00 mA, retrim starting at Item 2 above.

NOTE: For specific values not given in Table 5-1, interpolation may be used.

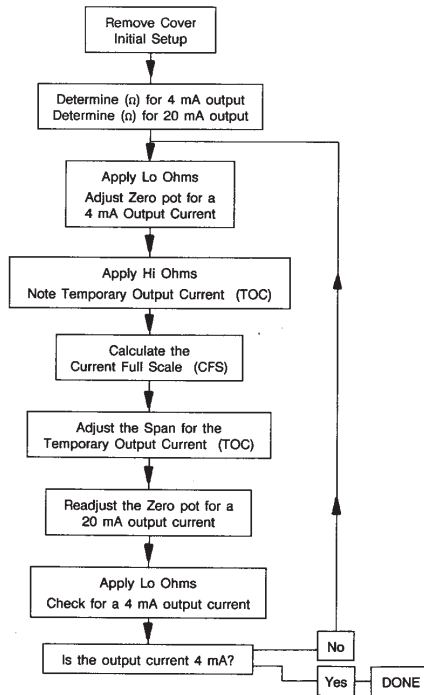

Figure 5-2 Calibration Flowchart

°C	Ohms	°C	Ohms	°C	Ohms
-200	18.49	150	157.31	500	289.90
-190	22.80	160	161.04	510	284.22
-180	27.08	170	164.76	520	287.53
-170	31.32	180	168.46	530	290.83
-160	35.53	190	172.16	540	294.11
-150	39.71	200	175.84	550	297.39
-140	43.87	210	179.51	560	300.65
-130	48.00	220	183.17	570	303.91
-120	52.11	230	186.82	580	307.15
-110	56.19	240	190.45	590	310.38
-100	60.25	250	194.07	600	313.59
- 90	64.30	260	197.69	610	316.80
- 80	68.33	270	201.29	620	319.99
- 70	72.33	280	204.88	630	323.18
- 60	76.33	290	208.45	640	326.35
- 50	80.31	300	212.02	650	329.51
- 40	84.27	310	215.57	660	332.66
- 30	88.22	320	219.12	670	335.79
- 20	92.16	330	222.65	680	338.92
- 10	96.09	340	226.17	690	342.03
0	100.00	350	229.67	700	345.13
10	103.90	360	233.17	710	348.22
20	107.79	370	236.65	720	351.30
30	111.67	380	240.13	730	354.37
40	115.54	390	243.59	740	357.42
50	119.40	400	247.04	750	360.47
60	123.24	410	250.48	760	363.50
70	127.07	420	253.90	770	366.52
80	130.89	430	257.32	780	369.53
90	134.70	440	260.72	790	372.52
100	138.50	450	264.11	800	375.51
110	142.29	460	267.49	810	378.48
120	146.06	470	270.86	820	381.45
130	149.82	480	274.22	830	384.40
140	153.58	490	277.56	840	387.34
				850	390.26

Table 5-1 DIN 43760 pt-100 Resistance

5.3 PIN ASSIGNMENTS (Jumper Pin-forest P1)

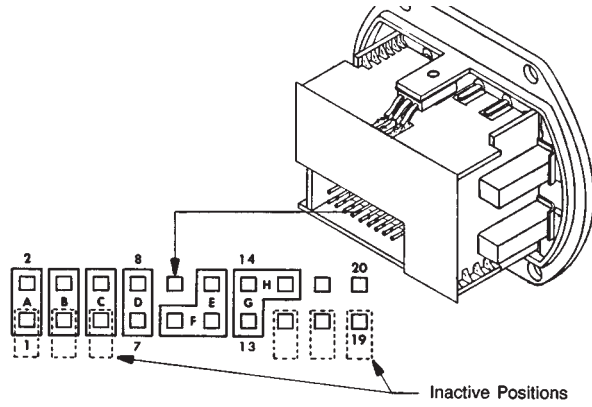

Figure 5-3 Jumper Diagram

NOTE: Always install 2 span jumpers

Jumper Function	P1 Pins Used
'A' Zero	1 and 2
'B' Zero	3 and 4
'C' Zero	5 and 6
'D' Zero	7 and 8
'E' Span	11 and 12
'F' Span	9 and 11
'G' Span	13 and 14
'H' Span	14 and 16

NOTE: P1 connector pins 10, 15, 17, 18, 19, and 29 are used solely for computerized testing by the factory.

—► INCREASING SPAN

Zero Jumper	Span Jumper F,H 100 to 300°C Span			Span Jumper F,G 300 to 400°C Span			Span Jumper E,H 400 to 600°C Span			Span Jumper E,G 600 to 1000°C Span		
	Base Temp	Min Temp	Max Temp	Base Temp	Min Temp	Max Temp	Base Temp	Min Temp	Max Temp	Base Temp	Min Temp	Max Temp
No Z Jumper							-500	380	645	600	875	850
D	-200	-136	100	-200	115	385	-150	360	600	-145	745	850
C	-170	-105	130	-138	195	455	70	535	620			
CD	-88	3	248	-75	315	540	40	670	660			
B	36	104	355	65	430	710	140	795	650			
B D	135	205	480	140	535	830						
BC	225	285	585	270	535	830						
BCD	308	390	690	340	640	830						
A	395	455	780	440	530	830						
A D	495	545	840									
A C	540	620	830									
A CD	610	690	890									
AB	690	770	890									
AB D	740	825	850									

—► INCREASING SPAN

Table 5-2 Span Ranges in Degrees Celsius Obtained with Jumpers

NOTE: The 501 has a slight variation in the input offset of the opamp. If the selected range be obtained with the jumpers designated in Table 5-1, move to the previous or next jumper and range selection.

NOTE: Store the unused jumpers between the bottom connector pins and the printed-circuit board as shown in Figure 5-3

—► INCREASING SPAN

Zero Jumper	Span Jumper F,H 24 to 115 Ω Span			Span Jumper F,G 116 to 208 Ω Span			Span Jumper E,H 209 to 301 Ω Span			Span Jumper E,G 301 to 393 Ω Span		
	Min* Res for 4 mA	Min Res for 20 mA	Max Res for 20 mA	Min* Res for 4 mA	Min Res for 20 mA	Max Res for 20 mA	Min* Res for 4 mA	Min Res for 20 mA	Max Res for 20 mA	Min* Res for 4 mA	Min Res for 20 mA	Max Res for 20 mA
No Z-Jumper				0	116	208	0	209	301	0	301	393
D	0	24	115	10	126	218	30	239	331	47	348	440
C	40	64	155	59	175	267	77	286	378	95	396	488
CD	83	107	198	102	218	310	120	329	421	138	439	531
B	123	147	238	142	258	350	160	369	461	178	479	571
B D	160	184	275	178	294	386	196	405	497	214	515	607
BC	192	216	307	211	327	419	230	439	531	247	548	640
BCD	223	247	338	242	358	450	260	469	561	278	579	671
A	252	276	367	270	386	478	288	497	589	307	608	700
A D	278	302	393	297	413	505	315	524	616	333	634	726
A C	303	327	418	321	437	529	339	548	640	357	658	750
A CD	325	349	440	344	460	552	362	571	663	380	681	773
AB	347	371	462	366	482	574	384	593	685	402	703	795
AB D	367	391	482	386	502	594	404	613	705	422	723	815
ABC	386	410	501	405	521	613	423	632	724	441	742	834
ABCD	404	428	519	423	539	631	440	649	741	459	760	852

—► INCREASING SPAN

* Maximum for 4 mA is the minimum for the next higher range.

NOTE: The 501 has a slight variation in the input offset of the opamp. If the selected range be obtained with the jumpers designated in Table 5-1, move to the previous or next jumper and range selection.

NOTE: Store the unused jumpers between the bottom connector pins and the printed-circuit board as shown in Figure 5-3

APPENDIX A

TRANSMITTER ACCURACY SPECIFICATIONS

The complex current-transmitter circuitry necessary to amplify, isolate, protect, and offset weak input signals while consuming only small amounts of power can distort the signal in many ways. Additional accuracy limitations occur in RTD transmitters, which require precise excitation, lead-resistance-effect cancellation and large zero-suppression ranges in order to obtain good sensitivity and linearity for high temperatures.

Many transmitter data sheets omit key accuracy factors and/or express performance in percentage values without mentioning the full-scale value. Design limitations can be disguised by such "specsmanship"; the 501 specifications, however, are detailed in order to present the complete performance accuracy.

Input errors are logically expressed in degrees (rather than ohms), and output errors are readily expressed in microamperes, since output is current. Transmitter users are rarely interested in microamperes, however, so these output current errors are translated back to input degrees as a percentage (or ppm) of the selected Span.

Another fundamental division of errors is that of independence or dependence on Zero and Reading. Resistor aging and tempco mismatch in the Zero and Voltage Reference circuits will produce errors which increase with Zero suppression but which are independent of the amount of Reading (value above the Zero). Resistor aging and tempco mismatch in the amplifier gain (feedback) circuits will usually affect both Zero and Reading accuracy; amplifier gain tempco variations are important to just the Reading stability. A complete error specification needs a term proportional to Zero (suppression) and a term proportional to Reading.

For RTD transmitters, the excitation current and amplifier offset tempcos are never precisely zero, even when factory-tailored over wide ambient excursions with curvilinear adjustments, as in the 501. This error component is readily stated as a percentage of the ambient temperature excursion from the nominal temperature at which the Zero was set (assuming, as in the 501, that the Zero potentiometer has ample resolution on all Zero and Span ranges). For transmitters with restricted turndown ratios (low zero-suppression capability), the tempco errors may be lumped into a single error term.

In addition to these three components of tempco (ambient temperature effects), there are other possible errors, often referred to as "time," "hysteresis," "repeatability," or "drift" errors. No statistically-significant errors of these types have yet been observed for the 501, which utilizes a solid-state, band-gap input voltage reference, matched-pair input PNP transistors, integrated-circuit current source and zero tempco control, and matched-tempco bridge resistors. The 501 also provides a variable-tempco output adjustment (factory-set) which eliminates many of the errors lumped in this category for other units. Its specification includes a 0.2°C tolerance for the calibration accuracies.